

**GARO**

WARRANTY  
**3**  
YEARS  
WARRANTY



# GEV7.4

## Charging Manual





## ELECTRIC VEHICLE CHARGER



**Model: GEV7.40 GEV7.4L**

**READ AND SAVE THESE INSTRUCTIONS**  
Installer: Leave this manual with the homeowner

# TABLE OF CONTENTS

<b>SAFETY INSTRUCTIONS</b>	3
<b>USER INSTRUCTIONS</b>	4
PARAMETERS SHEET	4
PRODUCT DESCRIPTION	5
PRODUCT DIMENSIONS	5
INDICATOR LIGHT	6
FUNCTION BUTTON	6
<b>INSTALLATION INSTRUCTIONS</b>	7
UNPACKING	7
ATTACHMENT	7
TOOLS/MATERIALS REQUIRED	8
BEFORE INSTALLATION	8
INSTALLATION LOCATION	8
CABLE ENTRY	9
ELECTRICAL WIRING	9
INSTALLATION	10
LOAD MANAGEMENT & SOLAR CTs	13
INSTALLATION OF THE CABLE HOLDER	15
SET THE CHARGER POWER	16
INSPECTION	16
<b>APP INSTRUCTION</b>	17
REGISTER	17
ADD DEVICE	17
<b>APP UTILISATION</b>	19
OPERATOR INTRODUCTION	19
FAULT INTERFACE	23
ALARM	24
<b>RFID REGISTRATION</b>	24
<b>MAINTENANCE</b>	25
<b>TROUBLESHOOTING</b>	25

# SAFETY INSTRUCTIONS

**Important note:** Please read this booklet before installing and switching on this appliance. The manufacturer assumes no responsibility for incorrect installation and usage as described in this booklet. Keep the instruction book for future reference. All the information in the manual is valid for the charging station model in this manual.

This instruction book details the install guidance for the charger. If you're unsure which model you have, please check the rating label on the charger.

The unit is designed for installations inside or outside, with the Innovative safety systems we have built into the charger ensuring its safe usage. This guidance provides information to assist when installing the unit. The charger must be professionally installed by a qualified electrician according to local and national regulations applicable at the time of installation and used in accordance with the manufacturer's instructions.

- This unit must be grounded (Earthed).
- This unit is only to be installed by a qualified electrician in accordance with local building and electrical codes and standards.
- This unit is designed to connect a electrical supply voltage of AC220V~240V 50/60Hz for single phase series .
- The charger must be installed on a secure solid flat surface that can support the weight of the charger. Failure to install on a secure surface or not in accordance with electrical regulations could lead to death, personal injury, or property damage.
- This appliance is designed to be used by adults, do not allow children to play with the appliance or let them hang over the charger.
- Do not put fingers into the socket or connector.
- This unit is not suitable for use in dangerous places where there is high amounts of dust, dangerous gas or in an explosive and flammable environment.
- In order to ensure the electrical safety of the unit, the product body shell must be fixed to the correct position with fasteners that come with the product and the seals used to ensure the IP rating is maintained.
- The unit's inlet position (front face) must be tightly sealed to be waterproof and dustproof to ensure the products IP rating.
- Do not use this unit other than its intended purpose.
- Do not use if the socket or connector or cable is damaged.
- Disconnect the charging from the vehicle prior to driving off.
- To prevent electrical shock, do not plug-in or un-plug with wet hands .
- Do not use a power washer to clean or wash the car charger.
- Do not install in areas where there is a high-risk chance of impact by vehicles or a high risk of trip hazard.

**Important:** Under no circumstances will compliance with the information in this manual relieve the user of his/her responsibility to comply with all applicable codes or safety standards.

# USER INSTRUCTIONS

## PARAMETERS SHEET

Item	Datasheet	Model	
		GEV7.40	GEV7.4L
Input	Power Supply	1P+N+PE	
	Rated Voltage	AC220 ~ 240V 50/60Hz	
	Rated current	Max 32A (6-32A adjustable)	
Output	Output Voltage	AC220 ~ 240V 50/60Hz	
	Maximum Current	Max 32A (6-32A adjustable)	
	Rated Power	7.4kW	
User interface	Charger socket or connector	Type 2	
	Material	ABS +PC Flammability Rating V - 0	
	Colour	Black	
	Indicator light	LED light	
Safety	Ingress Protection	IP55	Enclosure: IP65 Connector:IP54
	PCB protection	Over current protection	
		Residual current protection (AC TYPE A 30mA, DC6mA)	
		Earth check	
		Over/Under voltage protection	
		Over temperature	
		PEN fault protection	
	Certification	CE,UKCA	
Certification Standard	EN 61851,EN 62196		
Power consumption	Standby power consumption	<10W	
Enviroment	Installation	Wall mounted	
	Work Temperature	-25 °C ~50 °C	
	Work Humidity	3%~95%	
	Work Altitude	<2000m	

### Required external protection

MCB + RCCB or RCBO

# USER INSTRUCTIONS

## PRODUCT DESCRIPTION

**GEV7.4L**

**GEV7.4O**



- 1. Front cover
- 2. RFID area
- 3. Working status indicator
- 4. Socket
- 5. Function button
- 6. Charger holder
- 7. Charging lead (7.5M)

## PRODUCT DIMENSIONS

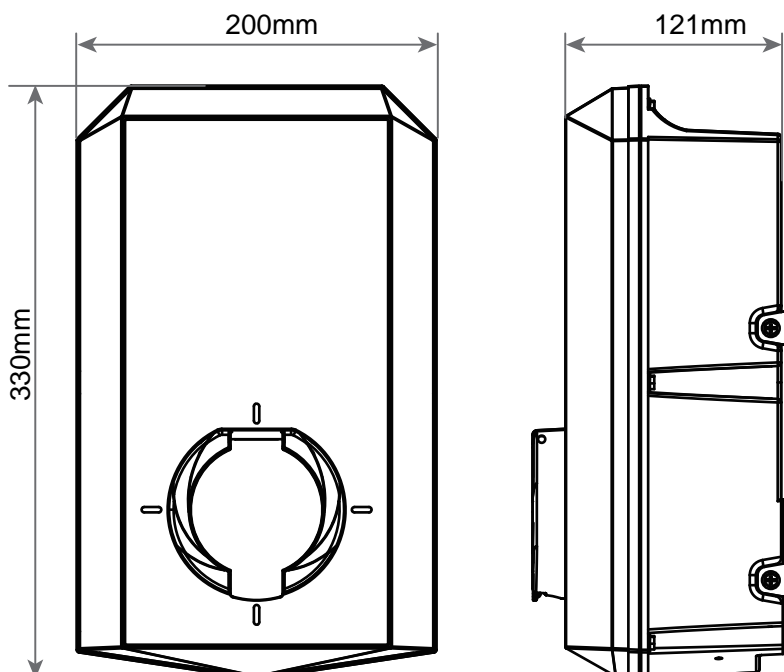

# USER INSTRUCTIONS

## INDICATOR LIGHT

Light Display Status	Product Status
Blue, green and red flashing alternately	Product power-on self-check
Blue light glowing	Standby
Blue light flashing	Connection confirmation
Green light glowing	Charging
Green light flashing	Charging Stopped by APP or OCPP
Red light glowing	Over temperature
Red light flashing one fast, one slow	Emergency stop
Yellow light glowing	Configuring

## FUNCTION BUTTON INSTRUCTION

Function	Operation	Status indicators	Remark
Emergency Stop	During normal charging, press once	Red light flashing One fast, one slow	Un-plug the connector
Mode Toggle	In standby state: Under APP control mode, press 5 times to enter plug and charge mode;(removes Random Delay) <b>Note:</b> plug and charge mode: automatically confirmed charging after the connection is confirmed	Beep twice	If you want to cancel the plug and charge mode, click schedule in the APP
Wifi Reset and Configuring URL/ID/APN	On standby statue, press and hold for more than 10 seconds to 1.Reset the WiFi, then re-add the device for pairing connection; 2. <b>Configure URL/ID/APN using Ethernet by PC</b>	Beep twice	1.The charger needs to be re-added to the APP 2.Restart the product power supply

## **RFID**

RFID function, you need to make sure that the connector is connected to the electric vehicle. In the connection confirmation mode, tap your card in the RFID area of the charger to start charging, and then tap your card in the RFID area again to stop charging.(see page 24)

**Note:** After starting and stopping charging once, tapping your card in the RFID area in connection confirmation mode will not continue to charge. If you want to continue charging, you need to unplug the connector and reconnect to the electric vehicle.

## **SOCKET LOCK**

The EV cable will be locked when the connector plugged into the EV car.

The EV cable will be unlocked when the connector is unplugged from the car or power is removed the charger.

## **TELECOMMUNICATION**

This product complies with the OCPP1.6J service protocol. After you set the URL and ID by the Phone/PC, and the network cable is connected to the Ethernet interface, the product will automatically connect to the server.

To set the URL and ID:

- 1(phone): Refer to the "**setting**" in the APP ; or
- 2(PC): Refer to "**Configure URL/ID/APN using Ethernet**".

# USER INSTRUCTIONS

## POWER MANAGEMENT INSTRUCTION

Product with power management function can self-regulate the output current to keep the total household electricity load not exceeding the total household current.

To set the maximum power after the product is connected to the WIFI, open the APP and go to settings and then input numerical value into "DLB value" . For detailed settings, please refer to "DLB value".

# INSTALLATION INSTRUCTIONS

## UNPACKING

- 1.Remove the sealing tape and take out the unit.
- 2.Follow the **ATTACHMENT** to check all items and to see if there are any omissions.
- 3.Check the unit is correct and whether it matches with order model.
- 4.Check whether the unit has defects or is damaged due to defectiveness or transportation.
- 5.Make sure all packaging is disposed of responsibly and in accordance with the current regulations in your region.

## ATTACHMENT

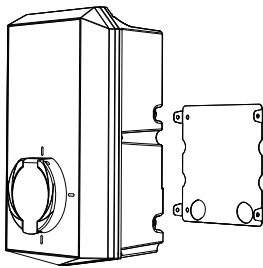

1 x EV Charger & 1 x Fixing bracket \*

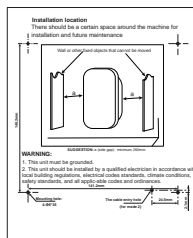

1 x Installation template



1 x Manual



1 x Elbow wrench



Wiring cap



Sealing rubber



Cable Gland



4 x Wall Plugs  
Φ6x30

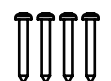

4 x Screw  
ST4.2x32

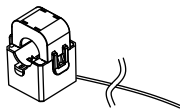

2 x CT\*\*



CT wire terminal\*\*



Sealing rubber\*\*\*

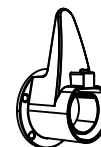

1 x Charger holder\*\*\*\*

\* NOTE: It is integrated from factory, and separated when installed.

\*\* Just for charger with power management

\*\*\* Both for charger with power management and OCPP

\*\*\*\* Just for Charger with cable.



# INSTALLATION INSTRUCTIONS

## TOOLS/MATERIALS REQUIRED (NOT INCLUDED)

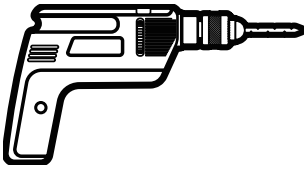

Electric drill

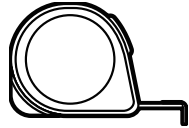

Measuring tape



Safety gloves

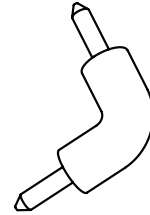

Electric elbow tool

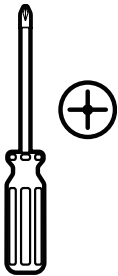

Posi 2 screwdriver

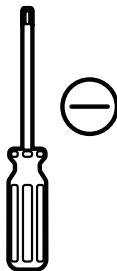

Slotted screwdriver

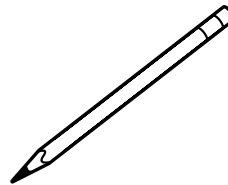

Pencil

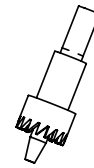

Hole Saws  
Mode 1:  $\Phi$ 24mm Bottom hole  
(for the single phase)  
Mode 2:  $\Phi$ 18mm (Back hole for  
Sealing rubber)

## BEFORE INSTALLATION

1. Installer or end user must read and understand all the content covered in this manual before installing or using this unit.
2. Choose a suitable installation location according to the installation conditions stated in the warning.
3. Make sure that the installation location complies with current laws and regulations.
4. Confirm that there is a suitable input voltage power supply at the installation site (consistent with the nominal power supply of the product).
5. Make sure the supplied fixings are suitable for the mounting location. If not suitable, alternatives must be obtained locally before proceeding with the installation.

## INSTALLATION LOCATION

There should be a certain space around the unit for installation and future maintenance.

### **SUGGESTION:**

a (side gap): minimum 250mm.

\*A charging cable holder position needs to be reserved. (Just for connector charger and cable)

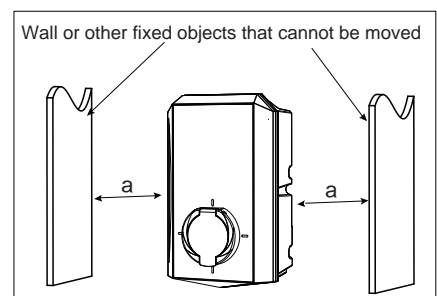

## WARNING

- ▲ Make sure that the power source is turned off before installing the unit.
- ▲ Manufacturers and distributors are not responsible for any loss or related responsibilities caused by any incorrect installation.
- ▲ The installer shall be responsible for the loss and damage of the product, system or property caused by improper installation.

# INSTALLATION INSTRUCTIONS

## CABLE ENTRY

### Important:

Before installing the unit, it is necessary to confirm the way of the product's power cable entry. Option 3 power cable entry is strictly prohibited.

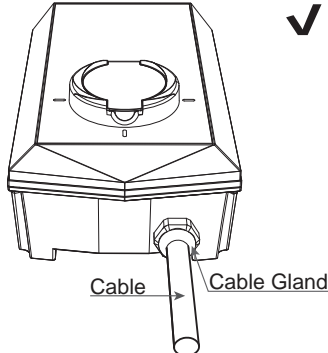
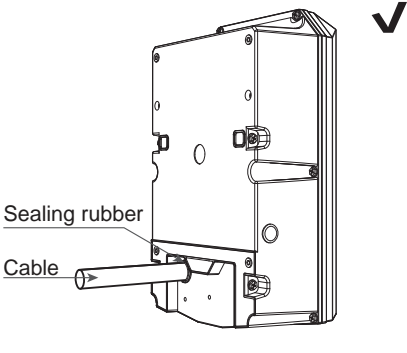
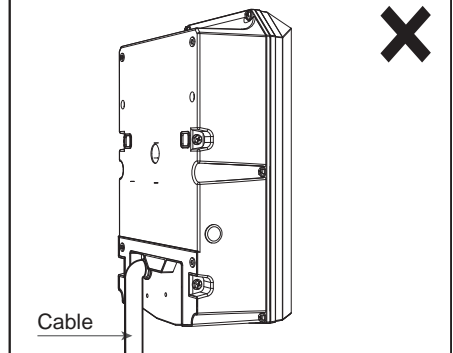
Option 1	Option 2	Option 3
Bottom entry (Best choice)	Back entry	It is strictly forbidden to pass the bottom line through the back.
		

## ELECTRICAL WIRING

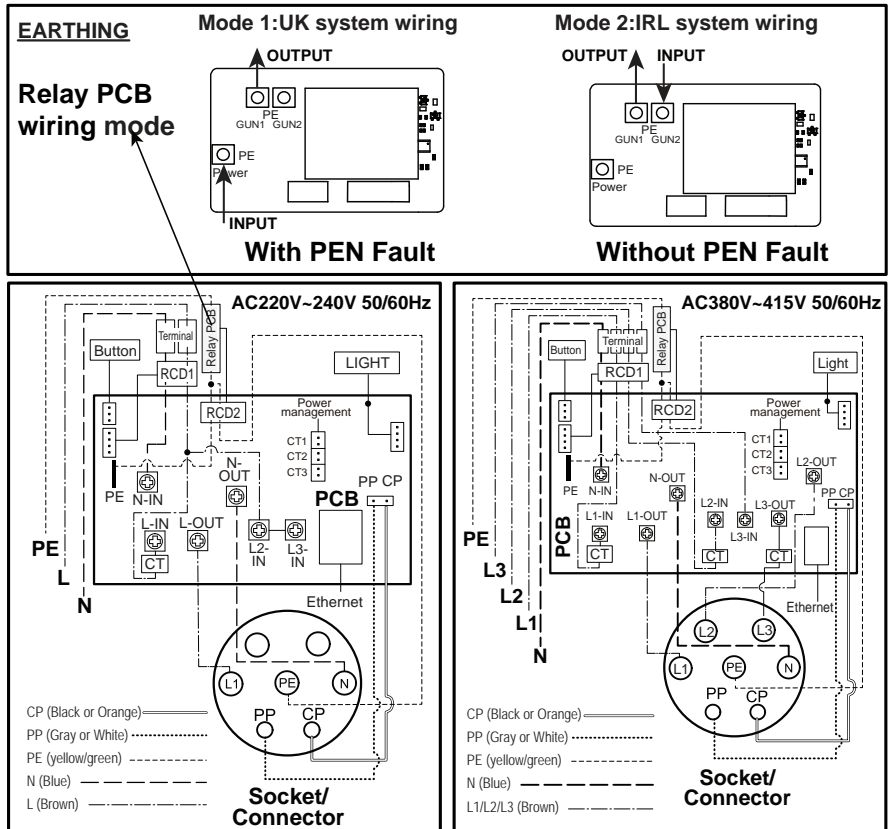
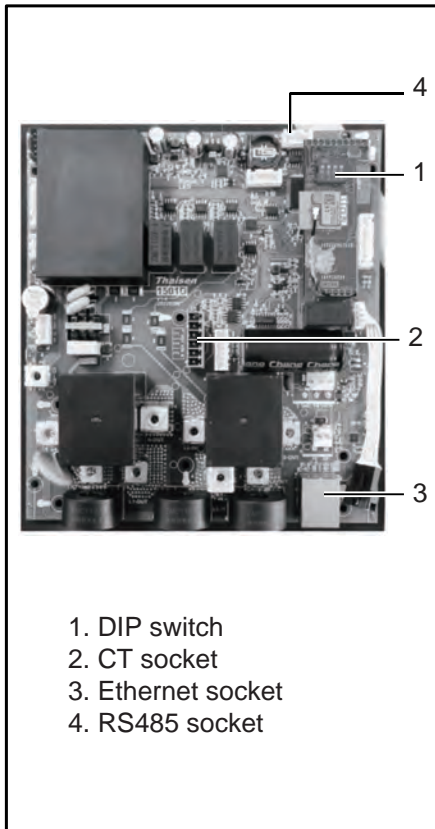

**Note :** The charger must be electrically protected by installing externally a Miniature Circuit Breaker (MCB) and a Residual Current Circuit Breaker(RCCB), or an RCBO.

**MCB:** Maximum value according to the maximum output current of the load point.

Reference SET THE CHARGER POWER.

**RCCB:** According to local regulations, Type A or Type B.

# INSTALLATION INSTRUCTIONS

## INSTALLATION

1. Take the unit and remove the 4 screws on its fixing bracket (The unit is integrated with the fixing bracket and needs to be disassembled first). Keep the screws and fixing bracket for subsequent use;
2. Remove the 6 fixing screws on the front shell and the rear shell, save the screws for subsequent use;  
**Note:** Reference Fig.1 for steps 1 and 2.
3. Open the front shell carefully. The front shell is connected to the unit body through a cable. Be careful not to damage or break the cable.

**Caution:** After opening the front shell, visually inspect the inside. If the wiring terminal block or the fixed component falls off the track, it can be installed back to the track by itself (reference Fig. 2)

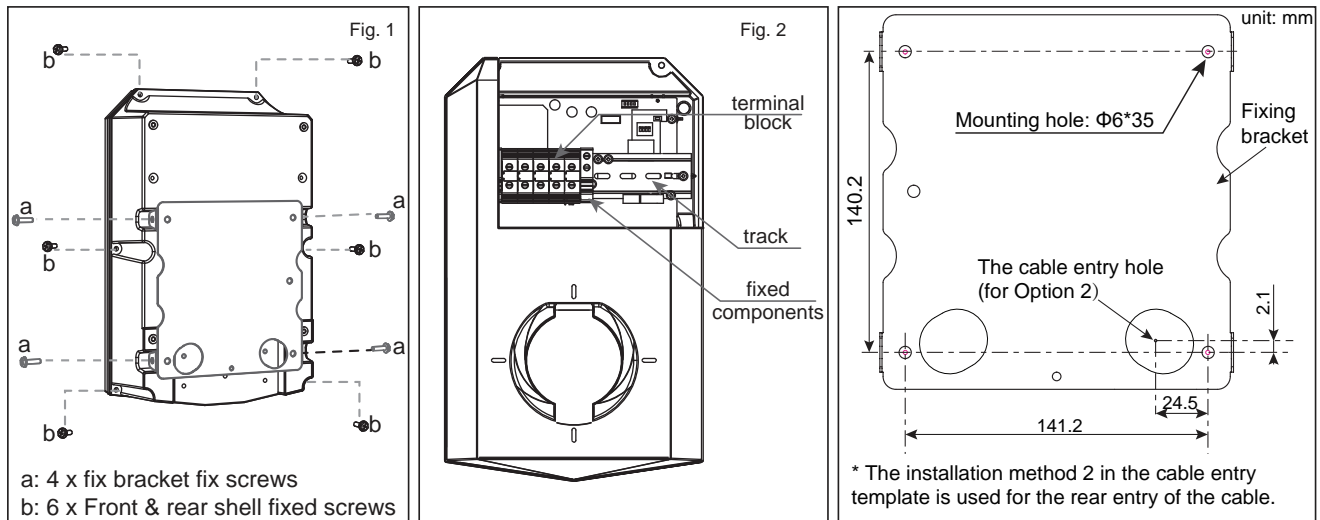

4. **Inlet wire Option 1:** use the installation template to mark the fixed bracket installation hole position.

**Inlet wire Option 2:** use the installation template to mark the position of the fixing bracket installation hole and the cable entry hole.

**Note 1:** Inlet wire option 2, pay attention to the correct direction of the installation template.

**Note 2:** Make sure that the installation template itself is level when the position is marked.

**Note 3:** Refer to Installation template.

5. Punch holes according to the punching information prompted by the installation template, and ensure that the punch positions are accurate.

(1). Fixed bracket mounting hole has a diameter of 6mm and a depth of about 35mm.

(2). Inlet wire option 2, diameter of the cable entry hole needs to be defined according to the actual cable selection, However, it is recommended that the maximum opening diameter should not be bigger than 24mm.

**Caution:** The edge of the wall opening needs to be repaired, and it must not be a sharp edge to prevent the incoming wire from being cut.

6. Fixing bracket installation hole inner - insert wall plugs, and use screws(ST4.2\*32) fixing fixed bracket to the mounting surface and ensure the screws are fastened well.

**Note:** If the screws are not fastened well, the fixing bracket may become loose and may interfere with the installation of the housing.

7. According to the size and position below, open the power cable hole on the shell.

**NOTE 1:** Inlet wire option1, open hole size must be accurate, and the hole diameter is Φ24mm (For single phase series) .

**NOTE 2:** Inlet wire option 2, open hole size must be accurate, and the hole diameter is Φ18mm.

**WARNING:** Remove burrs around the hole to prevent affecting the seal level.

**WARNING:** Do not damage internal components, especially internal wiring, when drilling the hole.

8. Clean and remove all the debris that has fallen into the shell due to the punching or drilling.

# INSTALLATION INSTRUCTIONS

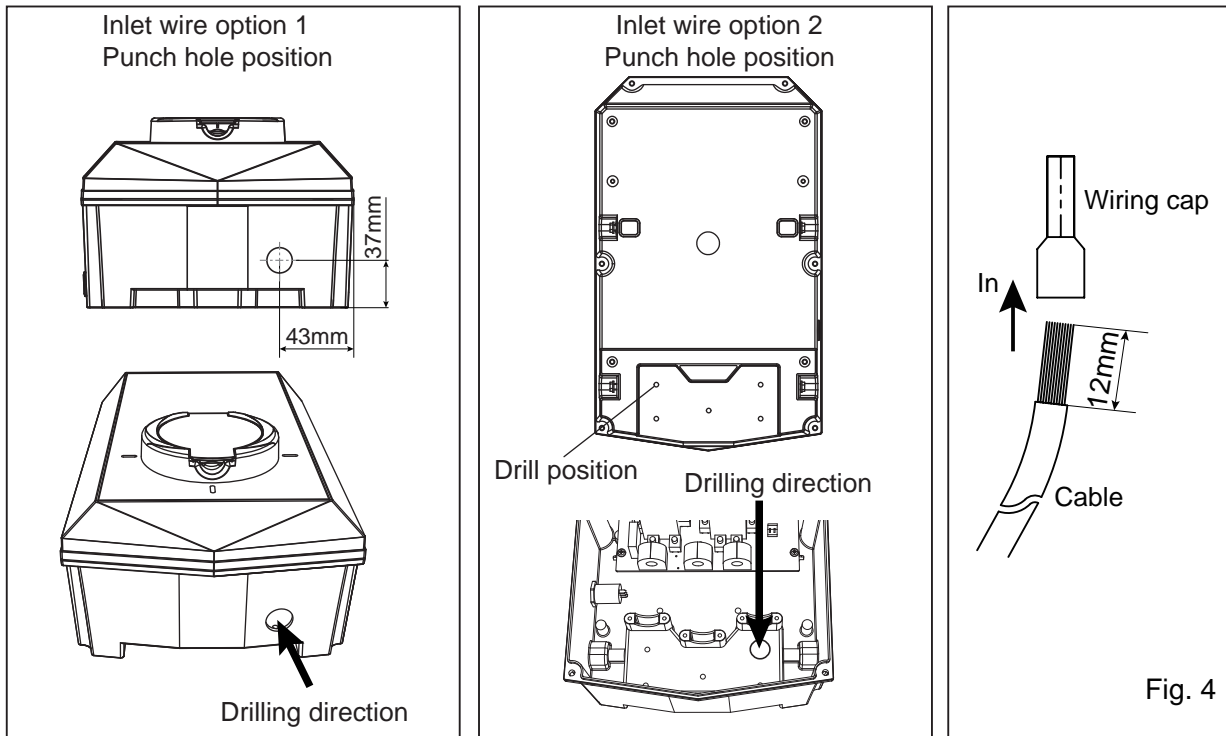

Fig. 4

## Network Connection guide

1. Drill holes according to Fig. 5.
2. Use the accessory sealing rubber to fix the network cable.
3. One hole of the sealing rubber be cut open with knife, insert the network cable into the sealing rubber, then insert them into the housing, as Fig.8; Reserve enough length of the network cable to ensure that it can be well connected with the Ethernet socket;

**NOTE:** During installation, if the network cable line and the plug is separate, you don't have to cut the sealing rubber.

**WARNING:** Seal the opening on the back to achieve the unit's IP rating.

Sealing is very important. This involves the safety of the product.

4. Network cable plug is docked to Ethernet socket.

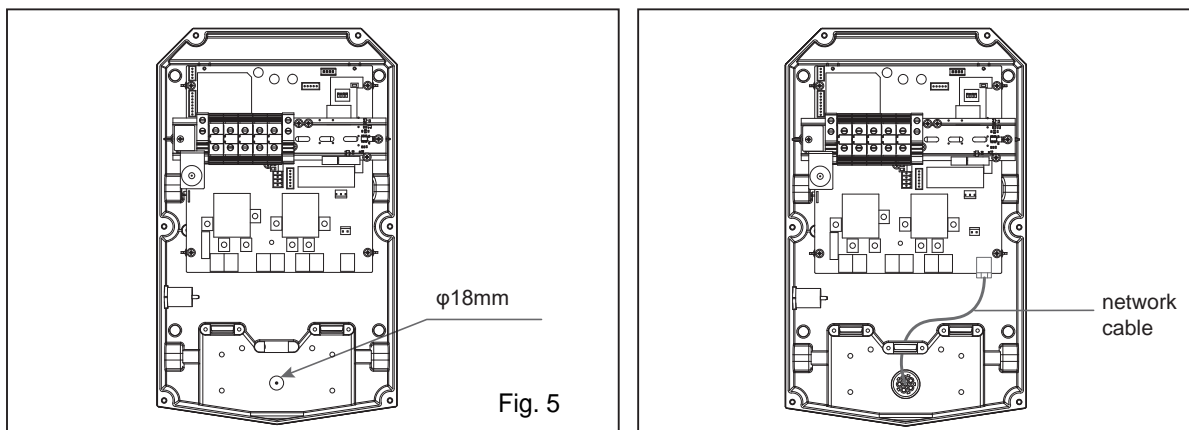

Fig. 5

\* **NOTE:** Product installation details with OCPP1.6J service agreement. Refer to “**Network Connection guide**”.

\*\* **NOTE:** Configure URL / ID / APN by PC. Refer to “**Configure URL/ID/APN using Ethernet**”.

\*\*\* **NOTE:** Product installation details with power management. Refer to “**Power management function installation guide**”.

# INSTALLATION INSTRUCTIONS

## Connecting to a BACK OFFICE

### Configure URL/ID/APN using Ethernet

**WARNING: This operation must be completed by qualified electrical installers.**

1. Power on the product, on the standby state (the blue light is glowing), press and hold the function button for 10s, when hearing beep twice (It is normal for the red light to flashing during this period), power off the product.

2. After power off the product, connect the product (Ethernet socket on PCB) with the PC by Ethernet cable with double-headed RJ45 plug;

**Note:** Please refer to the wiring diagram for the Location of Ethernet socket on PCB.

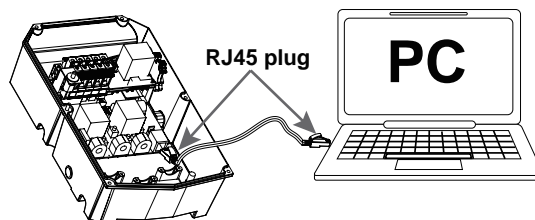

3. Re-power on The product, waiting for the BLUE light to turn YELLOW, the product has now entered the configuration state;

4. Use PC to adjust network properties. Configure internet Protocol version 4 (TCP/IPv4) parameters.

IP address: **192.168.1.26**

Subnet mask: **255.255.255.0**

IPv4 gateway/Router: **192.168.1.1**

**Important:**

1. This can be found in the Control Panel on your laptop.

2. DNS does not need to be filled in.

5. Open the Web (Google) Enter **192.168.1.30** to enter the configuration interface.

**Important:** The website must be **:192.168.1.30**.

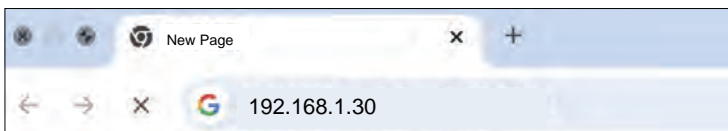
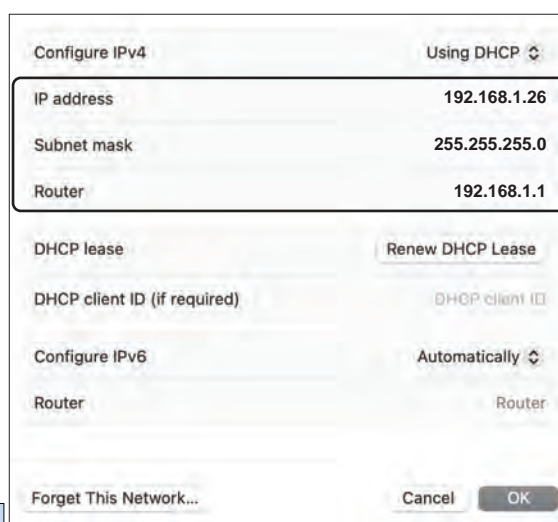

6. After entering the configuration page, you can set ChargeID (Maxlen 32), Server URL (Maxlen 100) and 4G APN:

**Note:** APN is only valid for 4G products.

<b>OCPP</b>	
ChargeID (Maxlen 32):	<input type="text"/>
Server URL (Maxlen 100):	<input type="text"/>
Firmware Version:	<input type="text"/>
Password:	<input type="text"/>
<b>4G</b>	
4G APN:	<input type="text"/>
4G Password:	<input type="text"/>
4G Account:	<input type="text"/>

7. After completing the filling, click submit to save, and then the configuration is completed.

8. Power off again, disconnect the Ethernet cable between the product and PC, and the charger needs to be connected to a network cable with signal (LAN). Power on, the charger will automatically connect to the server to enable back Office control. The GARO APP will no longer control the charger. Disconnect from back office to connect via GARO APP.

**Note 1:** network cable with signal such as a router network cable.

# INSTALLATION INSTRUCTIONS

## Power management function installation guide

1. Drill holes according to Fig. 5.
2. Use the accessory sealing rubber to fix the CT wire.
3. Insert the sealing part into the housing body, as Fig. 8, thread the CT wire into the sealing part, one hole corresponds to one CT wire (if the product is single-phase, just need to use a sealed wire hole, and the other two do not need to be pierced broken), after the CT cable is inserted, reserve enough length to connect to the CT interface;
4. Crimp the CT wire to the CT wire terminal and then insert it into the CT interface, as following Fig. 6
5. Open the CT and fixed it to the main incoming line (one CT is only allowed to pass through one line).

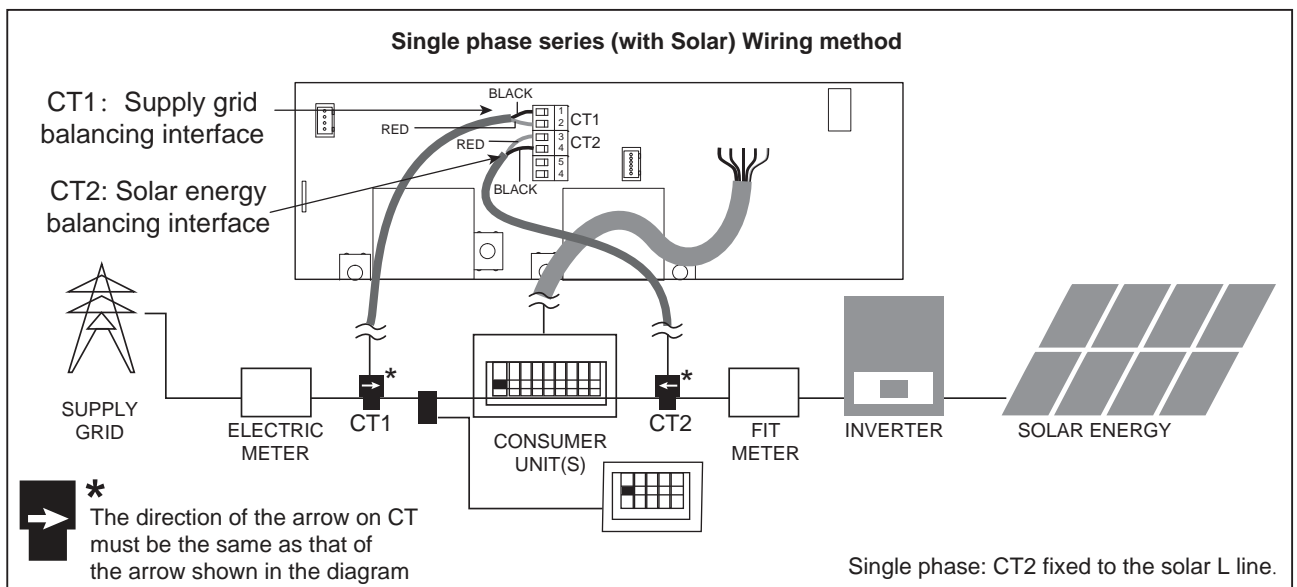
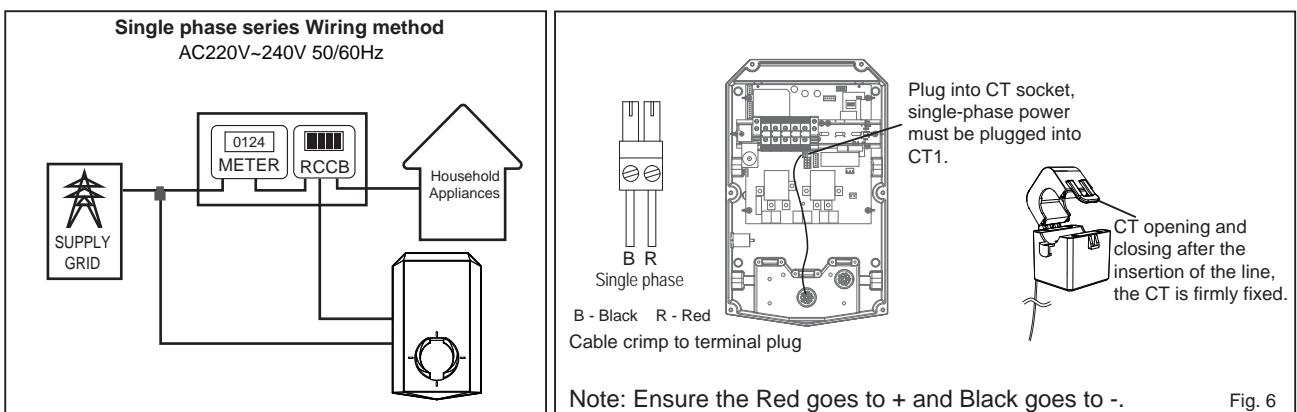

### NOTE:

If there is a need to extend the CT cable, **twisted-pair cable (CAT5) must be used**. DO NOT use mains cable, bell wire or speaker cable.

It is important to use only twisted-pair cable to maintain signal integrity. Up to four CT cables can be extended using the separate twisted pairs in a CAT5 Ethernet cable. The cable can be extended up to 40m.

#### • IMPORTANT: Separated twisted pair for each CT.

• When joining CT wires make sure that the ends of the wires are twisted tightly together and joined using crimps, screw terminals or solder.

• Avoid using lever clamp type terminals as these do not provide a reliable connection at very low currents.

# INSTALLATION INSTRUCTIONS

## OPTION 1

a1. Check the cable gland parts as shown in Fig. 7.

a2. Pass the gasket and the main body through the opening hole of the shell and lock it with a nut, as shown in Fig. 8

a3. Insert the pressing head into the cable, and then thread the cable into the main body that cannot be pulled off, as shown in Fig. 9.

a4. Trim and cut the cable to the proper length, lock the pressing head to secure the cable.

a5. Connect the cable to the terminal block.

**NOTE:** connecting wiring reference Fig. 4

**WARNING:** To ensure the rated IP protection level of the product, must use the cable gland in the accessories.

a6. Confirm and remove the debris inside the housing caused by punching and wiring.

a7. Ensure that all cables are connected correctly and securely, and are not lose or damaged.

a8. Screws lock the front and rear shells tightly.

**Caution:** Need to use the screws removed from the original position.

Before installing the front shell, it must be ensured that the sealing strip in the front shell groove has not fallen off and is in the right position. Ensure that all seals performed on the unit can reach the IP rating.

a9. Screw the unit to the fixed bracket.

**Caution:** Use the screws removed from the original position.

**Note:** a8, a9 refer to Fig. 1, reverse operation.

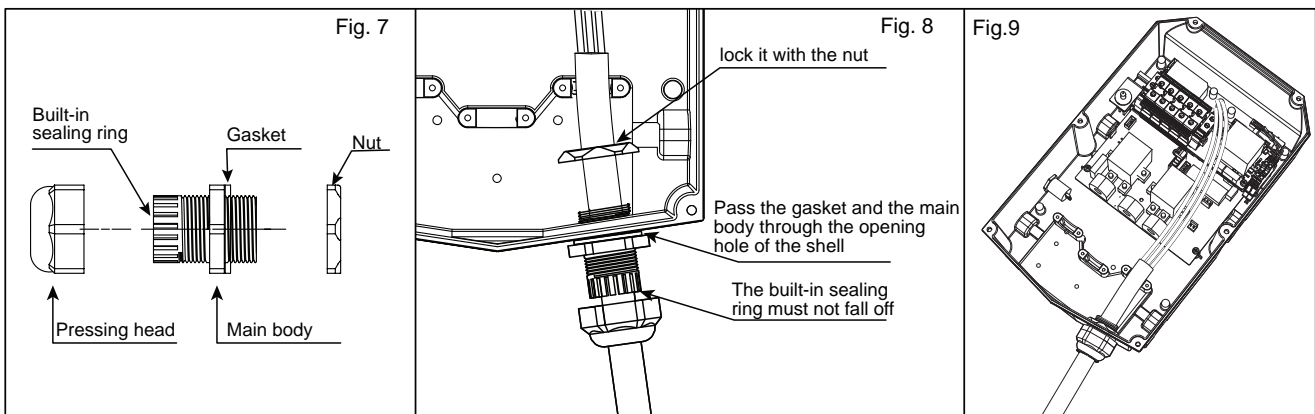

## OPTION 2

b1. Insert the sealing rubber into the housing, as shown in Fig 10, insert the bare wire into the sealing rubber, one hole corresponds to one bare wire, after all the wires are inserted, leave enough length of the cable to connect to the terminal block.

**NOTE1:** To ensure the rated IP protection level of the product, use the sealing rubber in the accessories.

**NOTE2:** Poke the middle position of the sealing rubber before installing this item.

b2. Screw fastening the entire rear shell to the fixing bracket.

**Caution:** Use the screws removed from the original position.

b3. Refer to this article connect electrical wiring to connect the cables to the terminal block.

**NOTE:** connecting wiring refer to Fig. 4

b4. Seal the opening on the back to achieve the unit's IP rating.

**Warning:** sealing is very important. This involves the safety of the product and must be paid attention.

b5. Screws lock the front and rear shells tightly.

**Caution:** Use the screws removed from the original position.

Before installing the front shell, it must be ensured that the sealing strip in the front shell groove has not fallen off and is in the right position.

Make sure that all seals performed on the unit can reach the IP rating.

**Note:** if there is no suitable electric tool, the elbow wrench provided in the accessories can be used to tighten the screws of the front and rear shells.

# INSTALLATION INSTRUCTIONS

**IMPORTANT NOTE:** It is the responsibility of the installing engineer to ensure that all cable terminations throughout this product are secure and tight and have not become loose, strained, or disconnected during transit and/or installation.

After the front and rear shells are installed, check whether there is a lap between the front and rear shells. Make sure that there are no gaps.

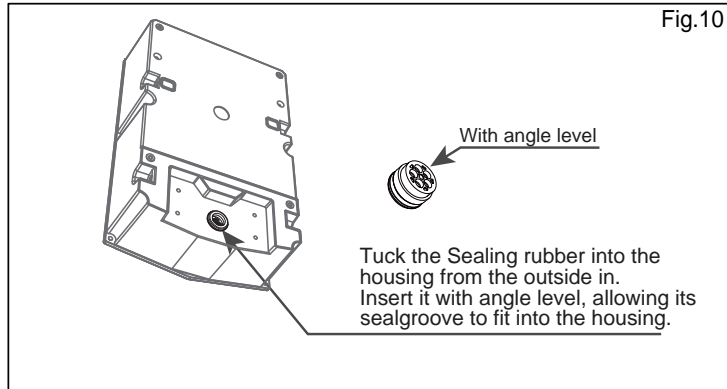

## INSTALLATION OF THE CABLE HOLDER

1. Take out the charger holder.
2. Find a suitable location near the EV charger box, which must be more than 0.5m above the bottom surface and not higher than 1.5m.
3. Align the charger holder in position and mark the four mounting holes.
4. Drill the 4 holes as the marks at dia 6mm, 35mm deep.
5. Insert the wall expansion plug.
6. Screw the charger holder to the wall.
7. Installation is complete.

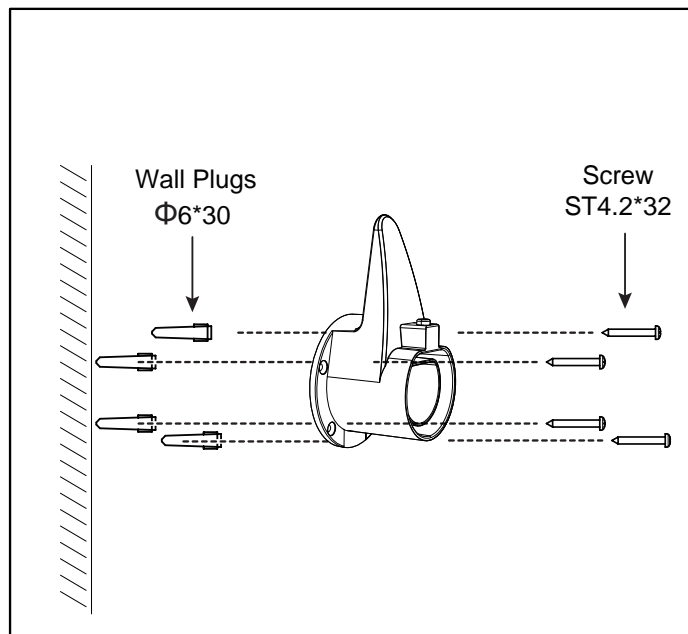
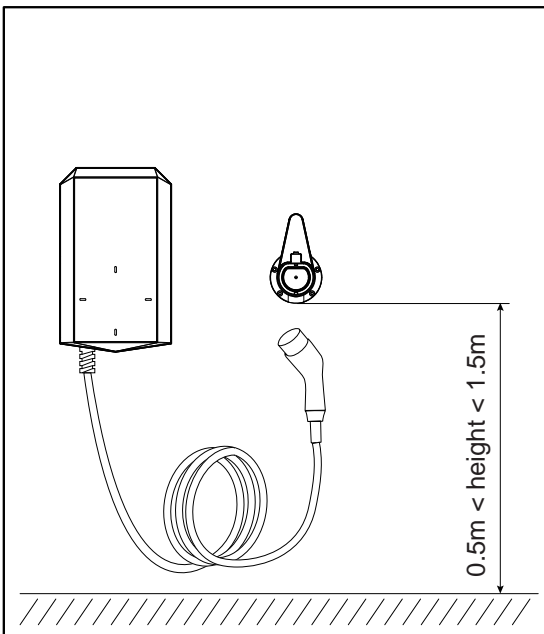

## THE INSTRUCTION FOR THE CABLE HOLDER

1. There is a clicking sound when the tip is inserted.
2. When pulling out the charger, you must first press the lock button and pull out the charger at the same time.



# INSTALLATION INSTRUCTIONS

## SET THE CHARGER POWER

You need to set the corresponding position of the current DIP switch according to the min. wire size shown in the chart and the rated current of the Circuit breaker. Refer to the steps below.



**Caution 1:** The following operations should only be configured with the power off.

**Caution 2:** Incorrect setting of DIP switches may cause hazards such as overheating of the incoming cable.



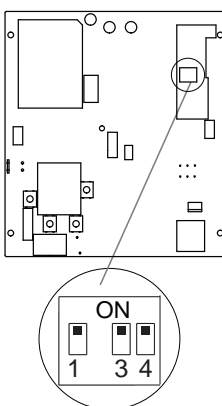

1. Locate the position of the two-position DIP switch on the power supply board.
2. Set the switch to the desired position:

**WARNING:** Electrical Power Switches must only be set by a qualified electrical installer. Incorrect setting may lead to equipment damage and / or personal injury. The current rating must not exceed the supply rating.



DIP switch position		
Current(A)	32	16
Min. wire size (copper)	6mm <sup>2</sup> or 10AWG	2.5mm <sup>2</sup> or 13AWG
Circuit breaker (Amps)	40	20

DIP switch position			DIP switch position		
Earth check	Yes	No	CT check	Yes	No

Dip Switch 1: "ON" 32Amps  
"OFF" 16Amps

DIP Switch 3: "ON" Charger checks Earth connection. If EARTH is not present, the Charger will not operate.  
"OFF" Charger does not check EARTH connection. If EARTH is not present, the charger will operate.

DIP Switch 4: "ON" Charger checks CT connection. If CT is not present, or connected the Charger will operate at 6 Amps.  
"OFF" Charger does not check CT connection. If CT is not present, the charger will operate normally.

**IMPORTANT:** For IRL, CT should be connected & DIP switch 4 must be turned to the "ON" position.

To Turn OFF default "Randomised delay": Press the External function button 5 Times. (see page 5)

To Turn ON default "Randomised delay": Press the External function button 5 Times. (see page 5)

To Turn OFF default "Off Peak Charging": Turn OFF in GARO APP

To Turn ON default "Off Peak Charging": Turn ON in GARO APP

**Factory DIP Switch settings:** SW1 ON SW3 ON SW4 OFF

## INSPECTION

1. Make sure you are satisfied that the installation is complete and is in a safe condition.
2. Switch ON the power, the Charger will cycle through red, blue and green lights to self-check and then enter the corresponding light indication. The unit should be tested in accordance with the current Electrical Wiring Regulations.
3. This product must be installed in compliance with the Electrical Wiring Regulations & Relevant Legislation.

# APP INSTRUCTION

## REGISTER

**Step 1.** Application platform download GARO APP : GARO DEV

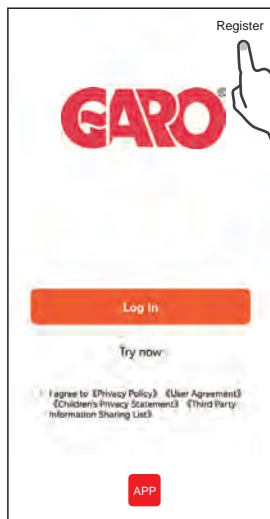

Step 2-1: Click Register



Step 2-2: Check the app agreement, enter the registered mobile phone number and click to get the verification code



Step 2-3: Input verification code.

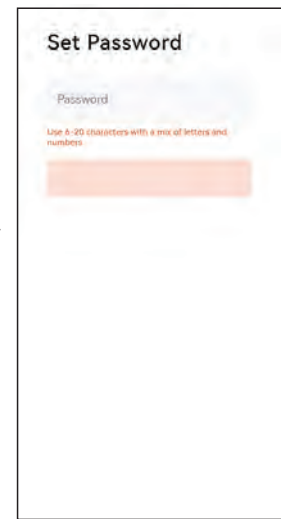

Step 2-4: Input the account login password and click done to complete the registration.

**Step 2.** Open the GARO app register an account to log in or log in directly through the relevant app bound.

**Note:** You can register your account through your mobile phone number or email. The following takes mobile phone number registration as an example to describe the steps in detail:

## ADD DEVICE

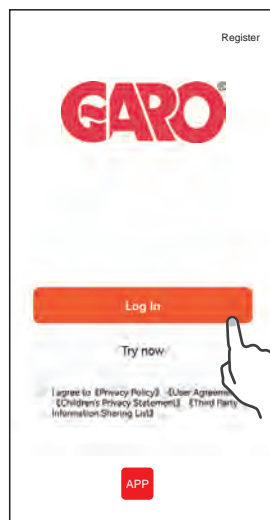

Step 3-1: Click log in

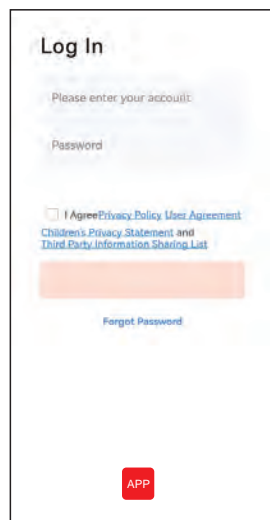

Step 3-2: Check the app agreement, enter the registered account and password, and click log in.

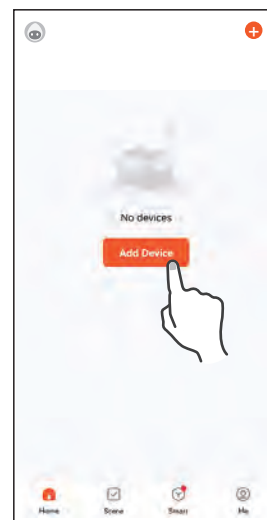

Step 4: Add device.



Step 5: Network and bluetooth not turned on.

**Step 3.** Check the app agreement, click log in, input the newly registered account and password to log in to the GARO app, and complete the app log in.

**Step 4.** Reset wifi (Hold the button down for 10s it will beep twice), Click "Add Device" to add the charger device that needs to be connected.

**Note:** Make sure the car is not plugged in to the charger.

**Step 5.** After turning on wifi, bluetooth and geolocation, they need to be enabled in the permissions. Click where it says turn on, and follow the guide to enable nearby devices. The tuya app automatically searches for connectable devices. **Note 1:** When connecting the device, the mobile phone must be close to the charger.

# APP INSTRUCTION

2. The charger needs to be connected to WiFi. If the WiFi signal is weak or absent, the charger will not receive the signal or delay the connection. Therefore it is recommended to add an enhancement device for WiFi receiving signal near the charger. Note: To check if your WiFi can reach the charger and have a good signal check your smart device or smart phone whilst standing close to the charger with the WiFi tuned on if the signal can be seen above 2 bars then it is ok if not a WiFi booster or repeater needs to be added.  
**Note:** The ethernet port is not for the smart App it is only for OCPP use.

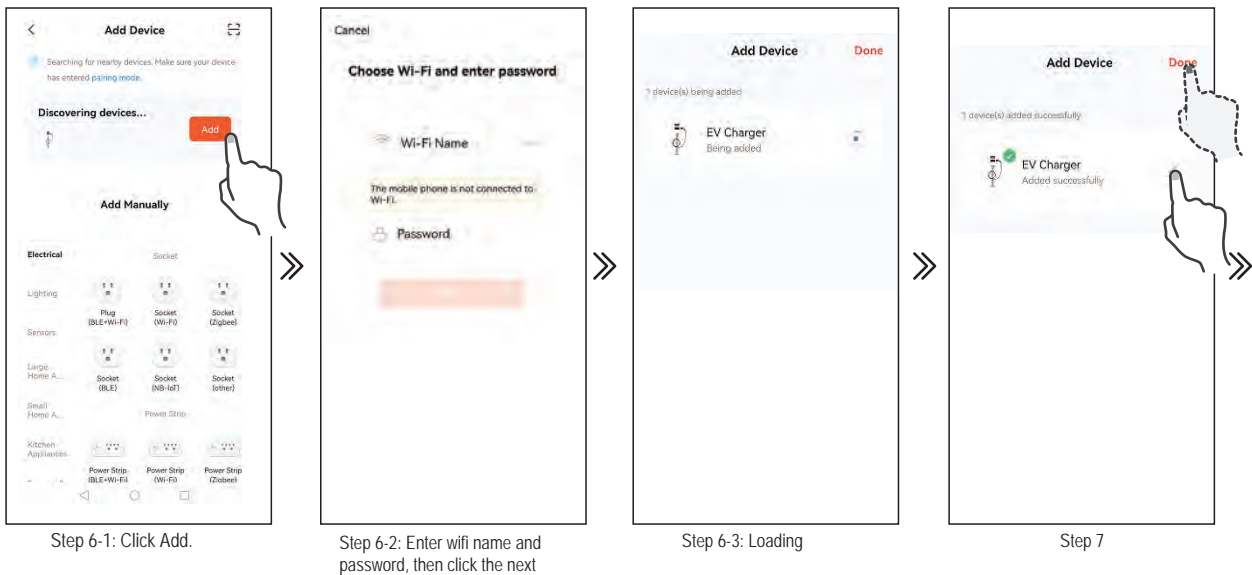

**Step 6.** After clicking ADD, enter the wifi and wifi password, wait for the device to connect to the network.  
**Step 7.** If you need define a new device name, click “✎” if not need, click “done” to confirm the connection is successful.

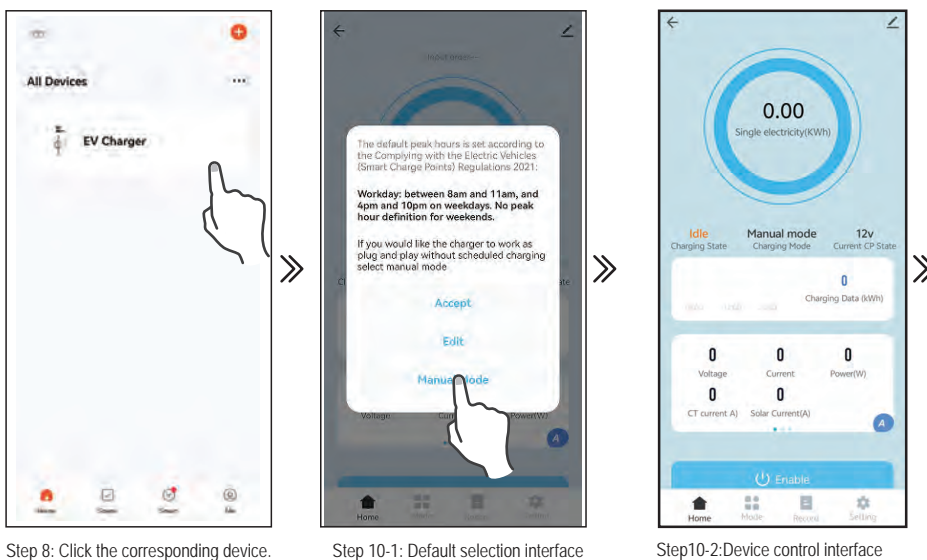

**Step 8.** Click the relevant device icon to enter the device control interface.  
**Step 9.** The first connection will appear the default selection interface, you can select the default mode, edit the charging time or select the manual mode.  
**Step 10.** Click manual mode.  
**Step 11.** After connecting to the electric vehicle, then charging without any operation.

# APP UTILISATION INSTRUCTION

## OPERATOR INTRODUCTION

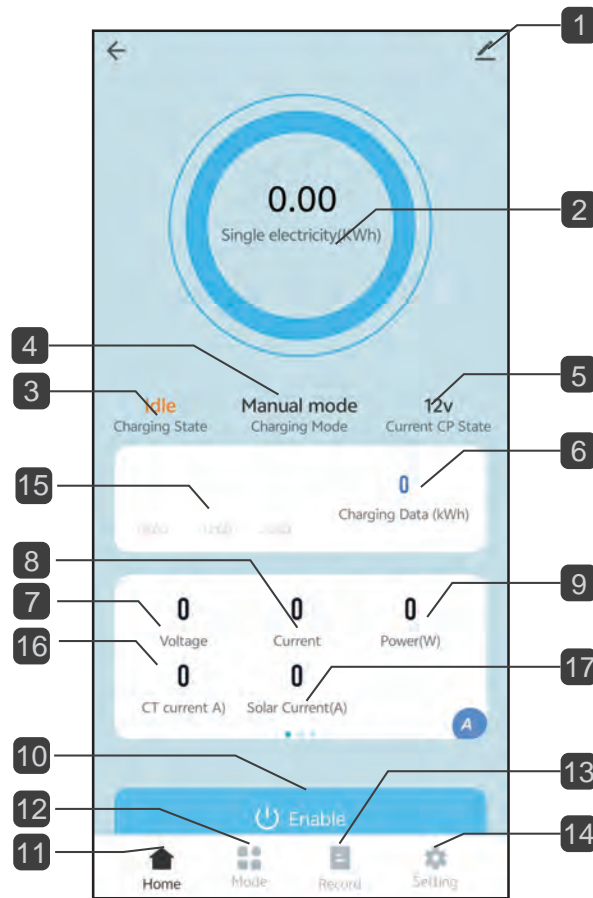

## INTERFACE INTRODUCTION

- |                                          |                              |
|------------------------------------------|------------------------------|
| 1 Edit                                   | 8 Charging current           |
| 2 Single charging energy consumption     | 9 Charging power             |
| 3 Charging state                         | 10 On/off                    |
| 4 Charging mode                          | 11 HOME                      |
| 5 CP state                               | 12 Charging mode             |
| 6 Cumulative charging energy consumption | 13 Record                    |
| 7 Charging voltage                       | 14 Setting                   |
|                                          | 15 Energy consumption record |
|                                          | 16 CT current                |
|                                          | 17 Solar current             |

# APP UTILISATION INSTRUCTION

## 1 Edit

(1). You can set the charger name by clicking "✎"

(2). **Offline Notification:** When the charger is powered off, it will prompt the device to be offline on the home screen.

(3). **Share Device:** You can share the APP with others by share device. Shared users only have the using right and cannot share the APP again.

Refer to the following steps:

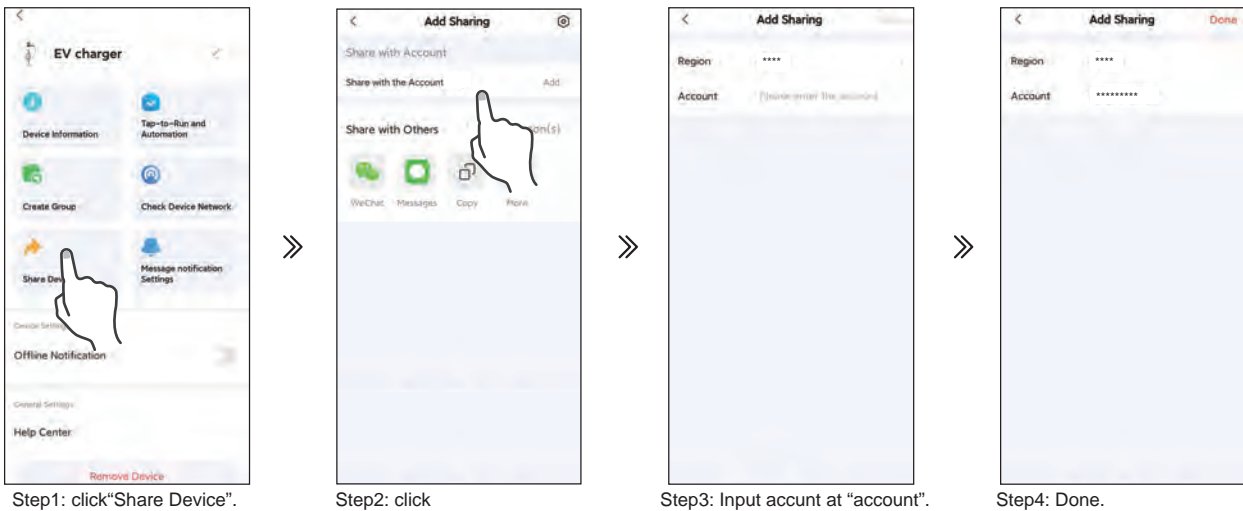

(4). **Software Update:** When there is a software update available a message will appear on the APP screen to confirm the update.

## (5). Remove Device

1. **Remove:** Disconnect device connection.

2. **Remove and Clear Data:** Disconnect device connection and wipe "Charging record" and "Error Log" data.

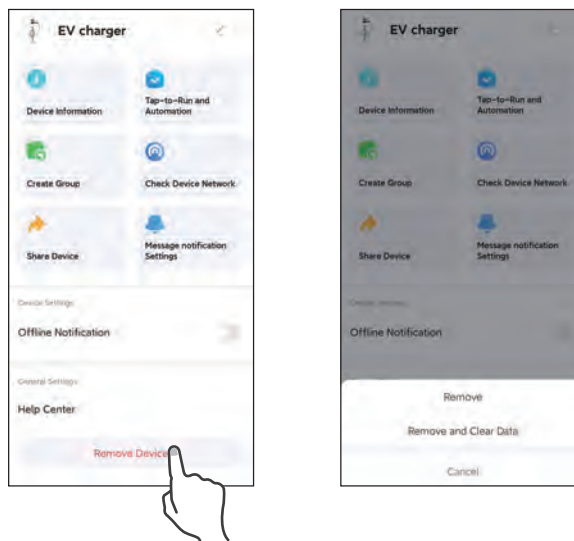

# APP UTILISATION INSTRUCTION

## 12 Charging mode

### 1. manual mode:

If **Manual mode** set “On”, you can not control by APP.

If **Manual mode** set “Off”, you must Enable charging by the APP or RFID card.

### 2. ECO(For solar): Optional (Only applicable to single phase model with solar load function).

The Charger will automatically adjust the charge rate based on the solar being generated. If the solar output drops below the specified minimum rate (e.g. sun goes behind a cloud) then the vehicle will charge at the minimum rate of 6A.

It is not advisable for a vehicle to repeatably stop and start charging and so the minimum rate will always guarantee charging and the extra power will be taken from the power grid.

When the charger detects more than 6A being generated by solar, the charger will increase the charge rate to make use of the solar energy and vary the charge rate based on the solar generation.

6A is the minimum that will charge an EV so can't be adjusted lower.

**Note:** Models without solar loads can only be charged at 6A using this option.

### 3. Schedule: Timed charging.

**NOTE 1:** When you choose the set time point to turn on the charging , you must adjust the hours setting, otherwise the default charging time is only 1 minute;

**NOTE 2:** When you choose the set time point to turn off the charging, there is no hours setting;

**NOTE 3:** When you choose the date choose, this time of each week will default to on or off charging.

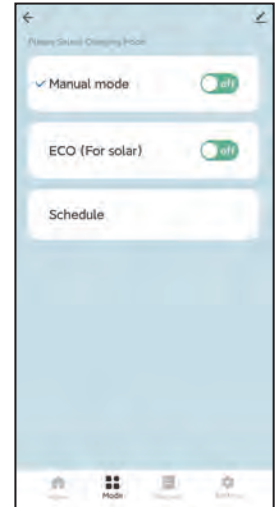

Charging mode

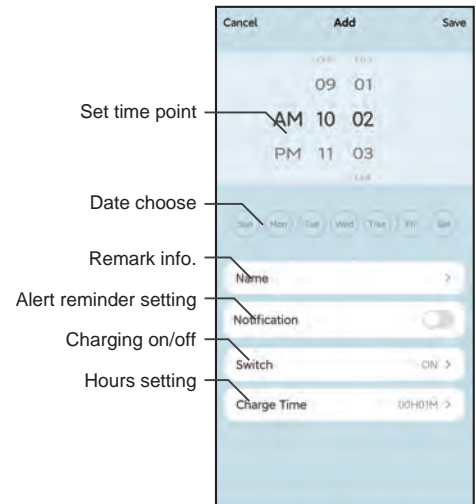

Charging mode

## 13 Record

You can view “**Charging record**” and “**Error log**” on this interface.

**NOTE:** Only the information that is turned on or off through the APP will be recorded in the charging record.

When the charging is turned on by the function button, there is no charging record.



Record

# APP UTILISATION INSTRUCTION

## 14 Setting

### 1. Input instruction:

**RFID No.:** You can input RFID card number for RFID product. Enter RFID number to bind the card;

**GNDON:** Monitoring the ground wire;

**NOTE:** This function is effective when "3" DIP switch is in the "On" position ;

**GNDOFF:** Cancel monitoring the ground wire;

**RESET:** Clear all charging data (After setting up, please power off and restart unit).

**2. Current setting:** You can set max charging current, max charging current not more than the current of DIP switch setting.

**NOTE 1:** After the APP is connected at the first time, the current value displayed here is not the set current value, it is a current setting form.

**NOTE 2:** It will take effect only after clicking to enter to set any current value, and the current value adjustment range is 6-32A.

**NOTE 3:** If the current value has never been set here, the value displayed here is invalid.

### 3. DLB: (Dynamic Load Balancing)

You can set power management from this tab, To use this function a CT clamp is required. To set maximum current:

3-1. Click DLB tab to enter command input field.

3-2. Input value, this value is the limited protection value of household entry current, the setting range is 0-999, and the factory default setting is **60** (the system will automatically optimize the current value when the actual value is 5 less than the value set): the setting value is recommended to be set according to the rated current value of the total household current.

**4. Temperature :** can check device interior temperature value.

**5. IP(URL):** Change the address of the OCPP back-office server.

Such as : wss://\*\*\*\*\*.\*\*\*/.

**Note:** Please don't ignore the last character "/", as it is very important.

**6. ID :** The product name in the OCPP back-office server.

**NOTE 1:** Make sure the ID is only.

**NOTE 2:** After the ID is replaced, it can be concluded that the ID replacement is complete

only when the Device number is consistent with the replaced ID;

If the Device number does not change after changing the ID, you can exit the APP and then power off and restart the EV charger.

**NOTE 3:** After the IP or ID is replaced, must be powered off and restarted to take effect.

### 7. Charging pile LAN address:

Only used for charger group management model, main charger code is 1300, subordinate charger code is 1301 - 1309.

If the charger group set up to the home charger, you need to enter 1555 here.

**NOTE:** Other code are invalid.

**8. RCD test:** Leakage protection test. When clicking on "RCD test", the device will report a leakage fault, and the APP will display "Pass" to indicate passing the test. Then click "Reset" to restore the device to normal, Complete testing.



Enter the URL  
wss://\*\*\*\*\*.\*\*\*/

Enter the ID  
(ID: The product name in the OCPP back-office server.)



Step 1: Click "RCD test"

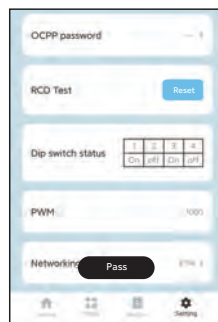

Step 2: Prompt "Pass".



Step 3: Click "Reset", Complete testing

# APP UTILISATION INSTRUCTION

9. **Dip switch status:** You can check the Dip switch status of the device through the APP.

10. These models does not include the following functions.

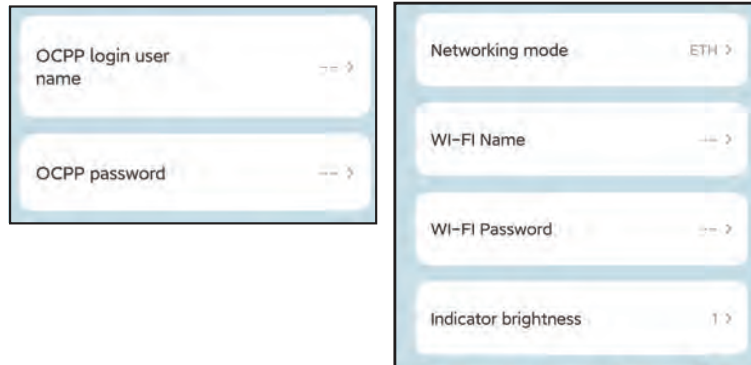

## FAULT INTERFACE

If device has fault, you can view the cause of the failure in the center of the main interface of the APP.

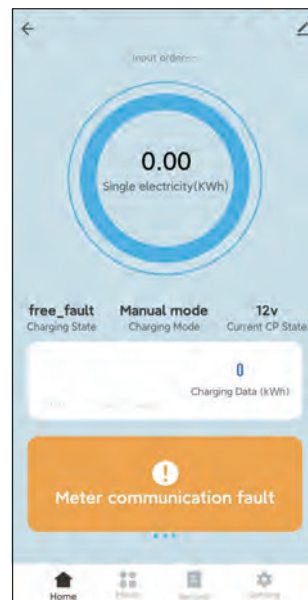



# APP UTILISATION INSTRUCTION

## ALARM

If there is unauthorized attempted access off the charger the charger software detects this tampering and this is reported via the APP.

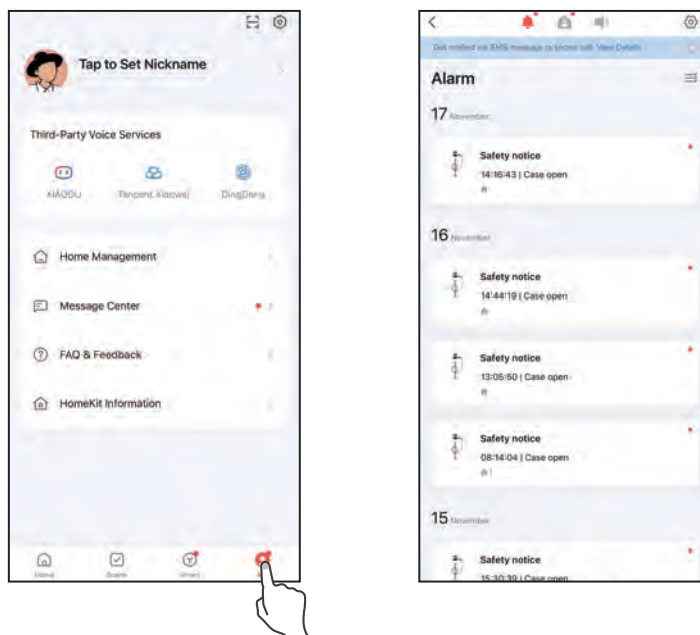

## RFID REGISTRATION

### Setup the RFID card for the customer

In the APP "**Setting**" interface, "**Input instruction**" option, enter the card No. on the front of the RFID card : **SPEVC#####** , then "Confirm".

**Note:**Do not use any spaces.

Test it by plugging in the car and swiping the card. Charging should start. If you get 2 bees, then the number is wrong or there was as space between the full stop. Both supplied cards have the same number so you only need to do this once.



RFID card

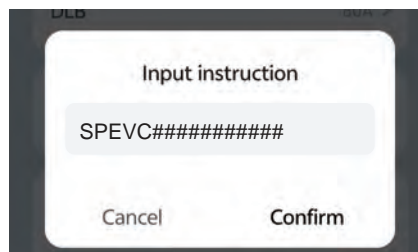

Setting interface

# MAINTENANCE

The charger enclosure does NOT need to be opened for routine maintenance tasks.

1. Regularly clean the external surfaces of the equipment with a damp cloth  
In order to avoid damaging the surface smoothness, do not clean the internal parts with soluble substances and alcohol.
2. Regularly inspect the exterior of the equipment for visual damage, if damage affects safety, isolate the equipment and prevent its use until appropriate repairs have been completed.
3. Once a year, the charger and switchgear (if installed) should be electrically inspected by an appropriately qualified electrician in accordance with the current legislation for the installation location. A record of the tests and results must be kept.

# TROUBLESHOOTING

## TROUBLESHOOTING

Red light flashing	One fast, two slow	CP fault
	Two fast, two slow	Leakage current fault
	Two fast, one slow	Over current
	Three fast, one slow	Leakage current fault
	Three fast, two slow	Under voltage fault
	Four fast, one slow	Over voltage fault
	Six fast, two slow	Adhesion fault
	Seven fast, one slow	Earth fault
	Red light glowing	Over temperature
	Six fast, three slow	Electronic lock fault
	Three fast, three slow	Free fault

**Note:** when the fault occurs, please try to unplug the gun or power off to restart.  
If the fault cannot be deleted, contact the after service department.

**Product Disposal**

In accordance with European Directive 2002/96/EC on waste electrical and electronic equipment and its implementation in national law, used electrical devices must be collected separately and recycled in an environmentally responsible manner.

Ensure you return your used device to your dealer or obtain information regarding a local, authorised collection and disposal system. Failure to comply with this EU Directive may result in a negative impact on the environment.

